

CERATIX 8466

Aromatic-free wax dispersion based on an EVA copolymer for solvent-borne effect coating systems to improve the orientation of effect pigments. It reduces settling of the effect pigments in the circulation pipe and in the container.

Product Data

Composition

Ethylene vinyl acetate copolymer wax dispersion (EVA)

Aromatic-free

Typical Properties

The values indicated in this data sheet describe typical properties and do not constitute specification limits.

Non-volatile matter (1 h, 257 °F):	4.7 %
Solvents:	Butylacetate/n-butanol 9/1
Flash point:	81 °F
Melting point (wax content):	212 °F
Viscosity (73 °F):	16 mPa·s

Food Contact Legal Status

For the current food contact legal status, please contact our product safety department or visit www.byk.com for further information.

Storage and Transportation

Temperature sensitive. To be stored and transported at a temperature below 35 °C. Mix well before use.

Special Note

Test method: Seeding

The wax additive is homogenized with a dissolver for 5 min at 4 m/s, then diluted with 20 % n-butylacetate and stirred for a further 2 min at about 4 m/s. A draw down is then made on a glass panel with a 100 µm doctor blade. The result must be clear during the drying and free from seeds.

Test method: Particle size measurement with a grindometer according to ISO 1524

The wax additive is homogenized with a dissolver for 5 min at 4 m/s. A draw down is then made on a 50 µm grindometer. Result: 20 µm fineness of grind.

Applications

Coatings Industry

Special Features and Benefits

The aromatic-free additive improves the orientation of effect pigments (aluminum, mica etc.), reduces large scale clouding and minimizes short wave defects (mottling, Bénard cells). It enhances the flip-flop effect and improves the leveling of the subsequent clear coating. Due to the special rheological properties of CERATIX 8466, it also reduces the settling of the effect pigments in the container and in the circulation pipe.

Recommended Use

The additive is recommended for all solvent-borne base coats and one coat top coats with effect pigments.

Automotive coatings	■
Industrial coatings	■

■ especially recommended

Recommended Levels

40-70 % additive (as supplied) based upon solid binder.

The above recommended levels can be used for orientation. Optimal levels are determined through a series of laboratory tests.

Incorporation and Processing Instructions

The wax additive must be homogenized before use with a dissolver (4 m/s) and then added to the binder solution under agitation. In systems with CAB, the CAB solution must first be incorporated homogeneously in the binder solution at high shear forces (> 5 m/s) before the stirred wax additive, the effect pigment slurry and the solvents can be added under agitation.

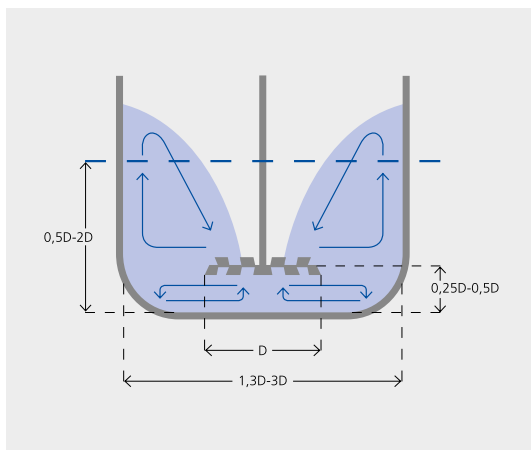

Special Note

CERATIX 8461 and CERATIX 8463 are two other wax additives which are very similar to CERATIX 8466. CERATIX 8463 is more polar than the other two and CERATIX 8466 is aromatic-free. Choosing the most suitable CERATIX type depends on the polarity of the base coat and of the clear coat. The choice can be determined by carrying out comparative testing.



BYK USA Inc.
524 South Cherry Street
P.O. Box 5670
Wallingford, CT 06492
USA
Tel 203 265-2086
Fax 203 284-9158

cs.usa@byk.com
www.byk.com

ANTI-TERRA®, BYK®, BYK®-DYNWET®, BYK®-SILCLEAN®, BYKANOL®, BYKETOL®, BYKJET®, BYKOPLAST®, BYKUMEN®, CARBOBYK®, DISPERBYK®, DISPERPLAST®, LACTIMON®, NANOBYPK®, PAPERBYK®, SILBYK®, VISCOBYK®, and Greenability® are registered trademarks of BYK-Chemie. ACTAL®, ADJUST®, ADVITROL®, ASTRABEN®, BENTOLITE®, CLAYTONE®, CLOISITE®, FULACOLOR®, FULCAT®, GARAMITE®, GELWHITE®, LAPONITE®, MINERAL COLLOID®, OPTIBENT®, OPTIFLO®, OPTIGEL®, PURE THIX®, RHEOCIN®, RHEOTIX®, RIC-SYN®, TIXOGEL®, and VISCOSEAL® are registered trademarks of BYK Additives. AQUACER®, AQUAMAT®, AQUATIX®, CERACOL®, CERAFAX®, CERAFLOUR®, CERAMAT®, CERATIX®, HORDAMER®, and MINERPOL® are registered trademarks of BYK-Cera. SCONA® is a registered trademark of BYK Kometra.

The information and data stated herein, although in no way guaranteed, are based upon tests and reports considered to be reliable and are believed to be accurate. No warranty, either expressed or implied, is made or intended. Use by a customer should be based upon their own investigations and appraisals. Any recommendation should not be construed as an invitation to use a material in infringement of patents. This issue replaces all previous versions – Printed in the USA